



PRODUCT FEATURES

- Seamless Illumination
- Spot Free Lens
- Line Voltage Integral Driver
- Even Illumination on Surfaces
- Easy Plug-and-Play Installation
- AC Power Driver Built In
- Round Opal Diffuser
- Quick Ship Available

PRODUCT SPECIFICATIONS

- Voltage: AC 120V
- Operating Temperature: 32-113°(0-45°C)
- Lamp Life: 50,000 hrs L70
- Available Color: 2700K, 3000K, 3500K, 4000K, (6000K for option)
- CRI/Ra >85
- Energy Efficiency: 75 lm/W - 5W/ft -375lm/ft
- Product is approved for Closet/Storage space installation per NEC410.16 (A) (3) and NEC410.16 (C)(5) per NRTL certification
- Degree of protection IP20 Beam Angle : 170°
- Finish: White
- 5 year Warranty

* Pending factory availability

DIMENSIONS

Model Number	Voltage Input (V)	Power Input (W)	A inches (mm)	B inches (mm)	C inches (mm)	B' inches (mm)	C' inches (mm)
ELS5-(Color)K-120V	AC 120	5	12.5" (319)	.95" (24.3)	1.29" (32.7)	1.06" (27)	1.4" (35.5)
ELS10-(Color)K-120V	AC 120	10	22.8" (580)	.95" (24.3)	1.29" (32.7)	1.06" (27)	1.4" (35.5)
ELS15-(Color)K-120V	AC 120	15	34.65" (880)	.95" (24.3)	1.29" (32.7)	1.06" (27)	1.4" (35.5)
ELS20-(Color)K-120V	AC 120	20	46.45" (1180)	.95" (24.3)	1.29" (32.7)	1.06" (27)	1.4" (35.5)

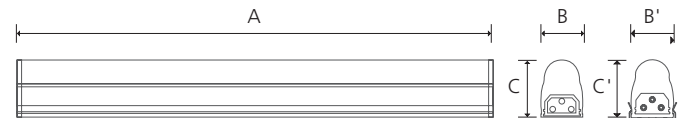

SPECIFICATION DIAGRAM

Power Options

Option 1 - Cord & Plug



Option 2 - Hardwire

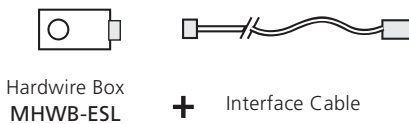

Fixture Connector Options

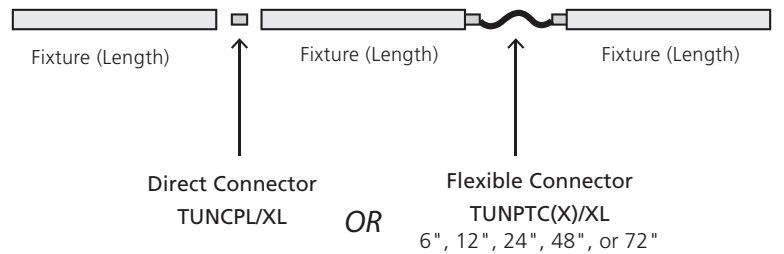

400 WATT MAX LOAD PER POWER CORD OR HARDWIRE BOX(NON-DIMMING)

LED: 400W

FIXTURES AND ACCESSORIES DIMENSIONS

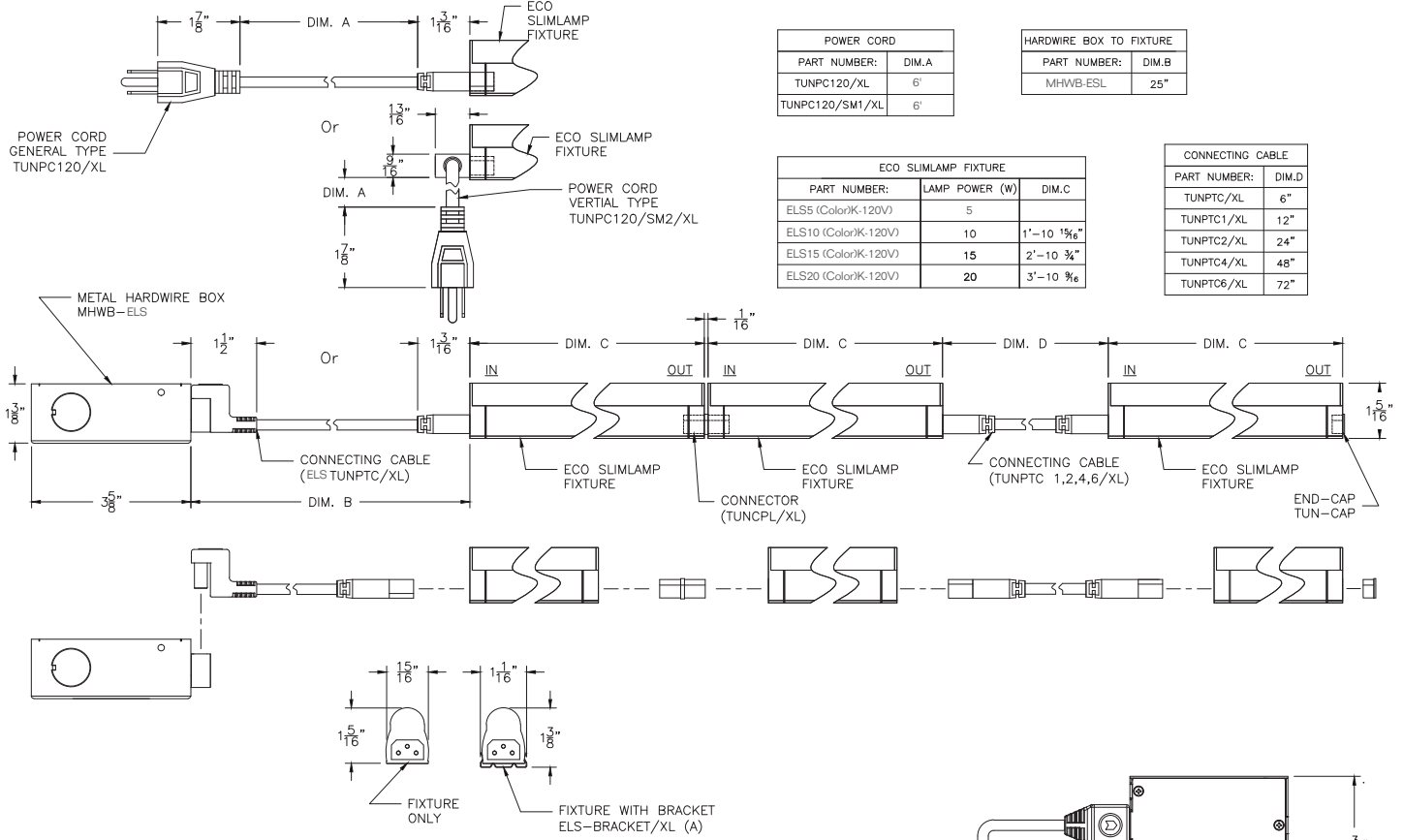

POWER CORD	
PART NUMBER:	DIM.A
TUNPC120/XL	6'
TUNPC120/SM1/XL	6'

HARDWARE BOX TO FIXTURE	
PART NUMBER:	DIM.B
MHWB-ESL	25"

ECO SLIMLAMP FIXTURE		
PART NUMBER:	LAMP POWER (W)	DIM.C
ELS5 (Color)K-120V	5	
ELS10 (Color)K-120V	10	1'-10 3/8"
ELS15 (Color)K-120V	15	2'-10 3/8"
ELS20 (Color)K-120V	20	3'-10 3/8"

CONNECTING CABLE	
PART NUMBER:	DIM.D
TUNPTC/XL	6"
TUNPTC1/XL	12"
TUNPTC2/XL	24"
TUNPTC4/XL	48"
TUNPTC6/XL	72"

BEAM SPREADS

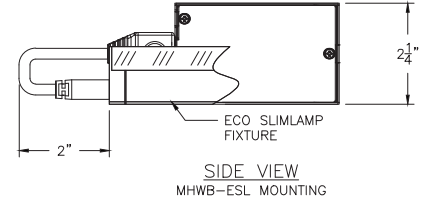
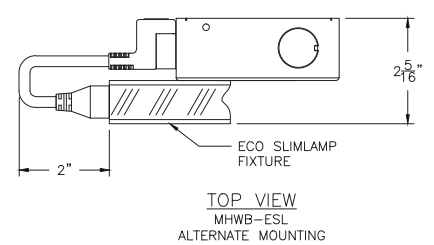
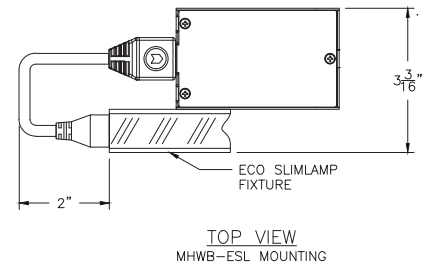
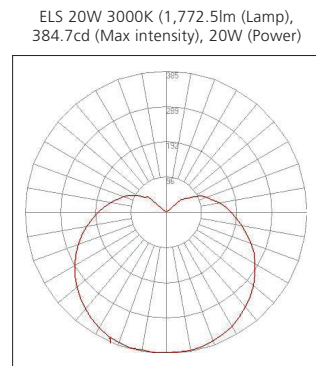
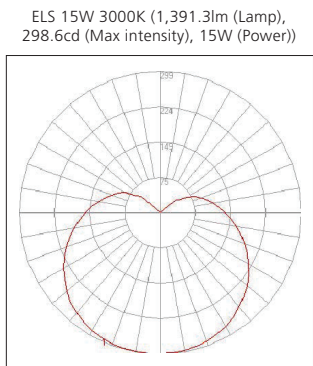
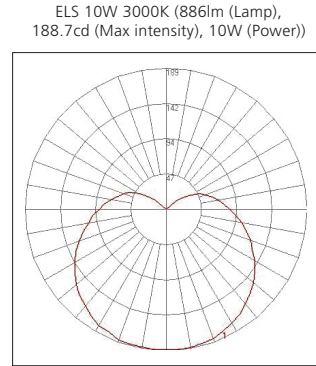
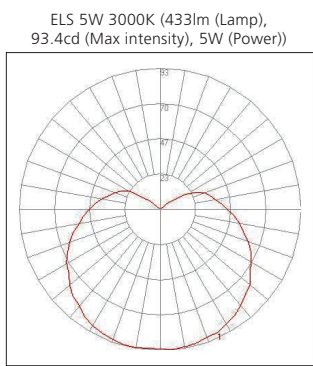

COMPONENTS

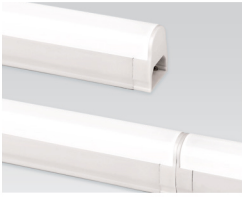

Fixture

- ___ ELS5W-(color)K-120V
- ___ ELS10W-(color)K-120V
- ___ ELS15W-(color)K-120V
- ___ ELS20W-(color)K-120V

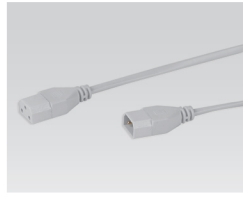

Jumper Cables

- ___ TUNPTC/XL (6")
- ___ TUNPTC1/XL (1')
- ___ TUNPTC2/XL (2')
- ___ TUNPTC4/XL (4')
- ___ TUNPTC6/XL (6')



Connector

- ___ TUNCPL/XL
- Included with fixture

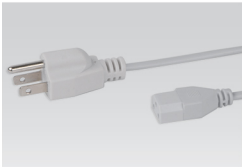

Power Cord (6')

- ___ TUNPC120/XL

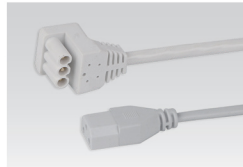

Interface Cables

- ___ ESLTUNPTC/XL (6")
- ___ ESLTUNPTC1/XL (1')
- ___ ESLTUNPTC2/XL (2')
- ___ ESLTUNPTC4/XL (4')
- ___ ESLTUNPTC6/XL (6')



End Cap

- ___ TUN-CAP
- Included with fixture



Power Cord (6')

- ___ TUNPC120/SM2/XL



Hard Wire Box

- ___ MHWB-ESL

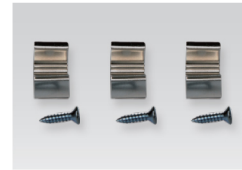

Mounting Brackets

- ___ ELS-BRACKET1
- Included with fixture

SPECIFICATION GUIDE: NOT TO BE USED FOR ORDERING. The Specification Guide is intended solely to ensure that all options are considered.

MODEL	COLOR	LENS	MOUNTING	CONFIGURATION	RUN LENGTH	POWER	ACCESSORIES	VOLTAGE
ELS		ST	STD•		ft.		NDM	120V
ELS	27K -2700K 30K -3000K 35K -3500K 40K -4000K 60K -6000K*	ST -Round Milky	STD - Flat Brackets Included	S -Straight V -Varies*	RUN LENGTH IN FEET 80ft max on single feed. Fill out for every run section	CP - Cable/Plug HW - Hard Wire	NDM Non-Dim	120V

***DRAWINGS AND RUN LENGTH REQUIRED**

*Check Factory for Availability